



INTERNATIONAL APPLICATION PUBLISHED UNDER THE PATENT COOPERATION TREATY (PCT)

<p>(51) International Patent Classification 6 : <b>E21B 43/10</b></p>	<p><b>A1</b></p>	<p>(11) International Publication Number: <b>WO 99/35368</b> (43) International Publication Date: 15 July 1999 (15.07.99)</p>
<p>(21) International Application Number: PCT/EP98/08549 (22) International Filing Date: 28 December 1998 (28.12.98) (30) Priority Data: 97204157.8 31 December 1997 (31.12.97) EP (71) Applicant (for all designated States except CA): SHELL INTERNATIONALE RESEARCH MAATSCHAPPIJ B.V. [NL/NL]; Carel van Bylandtlaan 30, NL-2596 HR The Hague (NL). (71) Applicant (for CA only): SHELL CANADA LIMITED [CA/CA]; 400 - 4th Avenue S.W., Calgary, Alberta T2P 2H5 (CA). (72) Inventors: LOHBECK, Wilhelmus, Christianus, Maria; Volmerlaan 6, NL-2288 GD Rijswijk (NL). MARKETZ, Franz; Volmerlaan 6, NL-2288 GD Rijswijk (NL). STEWART, Robert, Bruce; Volmerlaan 6, NL-2288 GD Rijswijk (NL).</p>		<p>(81) Designated States: AL, AM, AT, AU, AZ, BA, BB, BG, BR, BY, CA, CH, CN, CU, CZ, DE, DK, EE, ES, FI, GB, GD, GE, GH, GM, HR, HU, ID, IL, IN, IS, JP, KE, KG, KP, KR, KZ, LC, LK, LR, LS, LT, LU, LV, MD, MG, MK, MN, MW, MX, NO, NZ, PL, PT, RO, RU, SD, SE, SG, SI, SK, SL, TJ, TM, TR, TT, UA, UG, UZ, VN, YU, ZW, ARIPO patent (GH, GM, KE, LS, MW, SD, SZ, UG, ZW), Eurasian patent (AM, AZ, BY, KG, KZ, MD, RU, TJ, TM), European patent (AT, BE, CH, CY, DE, DK, ES, FI, FR, GB, GR, IE, IT, LU, MC, NL, PT, SE), OAPI patent (BF, BJ, CF, CG, CI, CM, GA, GN, GW, ML, MR, NE, SN, TD, TG).</p> <p>Published <i>With international search report. Before the expiration of the time limit for amending the claims and to be republished in the event of the receipt of amendments.</i></p>

BEST AVAILABLE COPY

(54) Title: METHOD FOR DRILLING AND COMPLETING A HYDROCARBON PRODUCTION WELL

(57) Abstract

A method for drilling and completing a hydrocarbon production well comprises the steps of: A) drilling a section of a borehole into an underground formation; inserting a casing into the drilled borehole section and radially expanding and securing the casing within said borehole section; B) lowering a drill bit through the expanded casing and drilling a subsequent section of the borehole; inserting a next casing into said subsequent section of the borehole and radially expanding and securing said next casing within said subsequent borehole section; and C) repeating, if required, step B a number of times until the borehole has reached the vicinity of a hydrocarbon bearing formation.

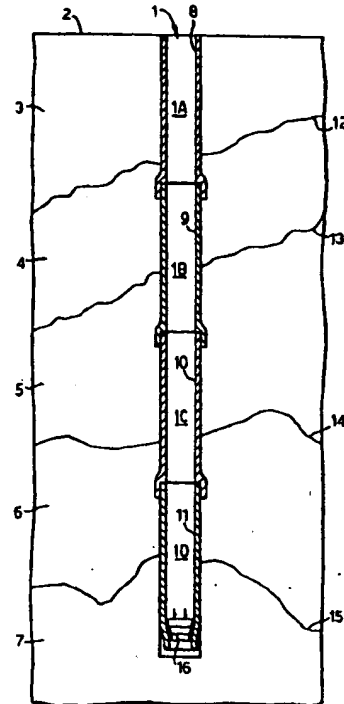

**FOR THE PURPOSES OF INFORMATION ONLY**

Codes used to identify States party to the PCT on the front pages of pamphlets publishing international applications under the PCT.

AL	Albania	ES	Spain	LS	Lesotho	SI	Slovenia
AM	Armenia	FI	Finland	LT	Lithuania	SK	Slovakia
AT	Austria	FR	France	LU	Luxembourg	SN	Senegal
AU	Australia	GA	Gabon	LV	Latvia	SZ	Swaziland
AZ	Azerbaijan	GB	United Kingdom	MC	Monaco	TD	Chad
BA	Bosnia and Herzegovina	GE	Georgia	MD	Republic of Moldova	TG	Togo
BB	Barbados	GH	Ghana	MG	Madagascar	TJ	Tajikistan
BE	Belgium	GN	Guinea	MK	The former Yugoslav Republic of Macedonia	TM	Turkmenistan
BF	Burkina Faso	GR	Greece	ML	Mali	TR	Turkey
BG	Bulgaria	HU	Hungary	MN	Mongolia	TT	Trinidad and Tobago
BJ	Benin	IE	Ireland	MR	Mauritania	UA	Ukraine
BR	Brazil	IL	Israel	MW	Malawi	UG	Uganda
BY	Belarus	IS	Iceland	MX	Mexico	US	United States of America
CA	Canada	IT	Italy	NE	Niger	UZ	Uzbekistan
CF	Central African Republic	JP	Japan	NL	Netherlands	YN	Yunnan
CG	Congo	KE	Kenya	NO	Norway	YU	Yugoslavia
CH	Switzerland	KG	Kyrgyzstan	NZ	New Zealand	ZW	Zimbabwe
CI	Côte d'Ivoire	KP	Democratic People's Republic of Korea	PL	Poland		
CM	Cameroon	KR	Republic of Korea	PT	Portugal		
CN	China	KZ	Kazakhstan	RO	Romania		
CU	Cuba	LC	Saint Lucia	RU	Russian Federation		
CZ	Czech Republic	LI	Liechtenstein	SD	Sudan		
DE	Germany	LK	Sri Lanka	SE	Sweden		
DK	Denmark	LR	Liberia	SG	Singapore		
EE	Estonia						

METHOD FOR DRILLING AND COMPLETING A HYDROCARBON  
PRODUCTION WELL

Background of the Invention

The invention relates to a method for drilling and completing a hydrocarbon production well, such as a well for the production of oil and/or gas.

5           Traditionally hydrocarbon production wells are created by first drilling a large borehole section in which a large diameter casing is inserted and cemented in place to stabilize the borehole wall. Subsequently a borehole extension of a smaller diameter is drilled and a  
10           casing is inserted into said extension such that said further casing extends from the bottom of said extension to the top of the borehole whereupon said further casing is cemented in place inside the borehole extension and also inside the previously set casing.

15           This process is repeated until the borehole reaches the vicinity of the hydrocarbon bearing formation. If that formation is unstable the casing is extended into that formation and subsequently perforated to enable inflow of hydrocarbons. If the hydrocarbon bearing  
20           formation is stable an essentially open hole is created in which a permeable production liner is inserted and surrounded by for example a gravel pack.

          The production liner is normally connected to the lower end of a production tubing which is lowered through  
25           the casing string such that it spans the length of the borehole from the wellhead until the vicinity of the hydrocarbon bearing formation, where the tubing is sealingly secured to the casing by means of a production packer.

Since the borehole wall and the inner surface of a previously installed casing may be irregular and the borehole may be curved significant clearances are required between the various casings and production tubing which results in a significant amount of unproductive annular space and redundant drilling work to be done.

Typically in a hydrocarbon production well the diameter of the upper part of the borehole near the earth surface and internal diameter of the upper casing part may well exceed half a metre, whereas the internal diameter of the production tubing through which hydrocarbons are produced is between 10 and 25 centimetres.

Numerous attempts have been made to reduce the amount of unproductive annular space in wells. US patent specifications Nos. 3,162,245; 3,203,483 and 5,014,779 disclose the use of originally corrugated tubulars which are expanded into a cylindrical shape against the inside of a casing by an expansion mandrel or sphere. A disadvantage of the use of corrugated tubulars is that they are difficult to manufacture and that the wall of the expanded tubulars may have non-uniformity of strength around their circumference which reduce their reliability.

International patent application, publication No. WO 93/25799 discloses the use of an essentially cylindrically shaped casing which is expanded against the borehole wall by an expansion mandrel so as to induce compressive force between the casing and surrounding formation.

This known expandable casing may be located between a surface casing arranged in an upper part of the wellbore and a production casing arranged in a lower part of the

wellbore. Since the surface and production casings are not expanded downhole this known well casing technique still either involves the use of conventional casing parts that require the drilling of an oversized borehole or the expansion of a casing string which is inserted and expanded after the full length of the borehole has been drilled, which is not always possible.

It is an object of the present invention to provide a method for drilling and completion of a hydrocarbon production well in which a casing can be installed or extended to protect the borehole wall against caving in during various phases of the drilling process and where installation of both the casing and production tubing can be achieved in such a way that along at least a substantial part of the length of the borehole the accumulated width of the annular spaces between the tubing, casing or casings and the surrounding formation is kept to a minimum.

It is a further object of the present invention to provide a method for creating a well in which the amount of steelwork required for casing and completing the well is kept to a minimum.

#### Summary of the Invention

The method according to the invention comprises the steps of:

- A) drilling a section of a borehole into an underground formation; inserting a casing into the drilled borehole section and radially expanding and securing the casing within said borehole section;
- B) lowering a drill bit through the expanded casing and drilling a subsequent section of the borehole; inserting a next casing into said subsequent section of the borehole and radially expanding and securing said next casing within said subsequent borehole section; and

C) repeating, if required, step B a number of times until the borehole has reached the vicinity of a hydrocarbon bearing formation.

5 Preferably only the first casing extends from the earth surface into the borehole and any subsequent casing only partly overlaps a previously set casing.

10 In such case it is preferred that the length along which subsequent casing sections overlap each other is less than 10% of the length of each casing itself and also that along at least a substantial part of the length of the borehole from the earth surface to the vicinity of the hydrocarbon bearing formation the variation in diameter of the borehole is less than 10%.

15 In that case a slim borehole of an almost uniform diameter along its entire length is created, which is drilled with a minimal amount of drilling effort and steelwork installed within the well.

20 In some circumstances, however, it may still be required that at least two casings that are subsequently inserted into the borehole each extend to the wellhead.

25 Furthermore, it is preferred that after installing said casings a production tubing is inserted into the borehole such that the production tubing extends from the earth surface to the vicinity of the hydrocarbon formation; and the tubing is radially expanded inside the string of expanded casings.

30 Suitably the casings and optionally the tubing are plastically expanded in radial direction by moving an expansion mandrel therethrough in a longitudinal direction and they are made of a formable steel grade which is subject to strain hardening without incurring any necking and ductile fracturing as a result of the expansion process and wherein an expansion mandrel is used which has along part of its length a tapering non-

metallic surface.

In such case it is preferred that the expansion mandrel has a tapering ceramic surface and that the tubing and casings are made of a formable steel grade having a yield strength-tensile strength ratio which is lower than 0.8 and a yield strength of at least 275 MPa.

It is also preferred that the production tubing and at least one of the casings consists of a tubular which is inserted into the borehole by reeling the tubular from a reeling drum.

Alternatively, the production tubing and/or at least one of the casings may be made up of a series of pipe sections that are interconnected at the wellhead by screw joints, welding or bonding to form an elongate pipe of a substantially cylindrical shape that can be expanded and installed downhole in accordance with the method according to the invention.

#### Brief Description of the Drawings

The invention will be described in more detail with reference to the accompanying drawings, in which

Fig. 1 is a longitudinal sectional view of a well comprising a series of radially expanded casings of substantially uniform diameter that have been installed using the method according to the present invention;

Fig. 2 shows the well of Fig. 1 in which a production tubing has been expanded within the series of casings;

Fig. 3 is a longitudinal sectional view of a series of telescoping expanded casings and of a production tubing that have been installed in accordance with the method according to the invention; and

Fig. 4 is a longitudinal sectional view of a production tubing which is expanded downhole by an expansion mandrel.

Detailed description of the Invention

Referring now to Fig. 1 there is shown a borehole 1 that extends from the earth surface 2 through a number of underground formation layers 3, 4, 5 and 6 into an oil and/or gas bearing formation layer 7.

In the example shown it is assumed that a casing 8, 9, 10 or 11 needs to be inserted to protect the borehole 1 against caving in each time when the borehole 1 has passed an interface 12, 13, 14 or 15 between different formation layers 3, 4, 5, 6 or 7.

Accordingly, initially the first and upper section 1A of the borehole 1 is drilled and after the interface 12 has been reached the upper casing 8 is inserted into the upper borehole section 1A and radially expanded by means of an expansion mandrel 16. The expanded casing 8 may be secured to the borehole wall by means of an annular body (not shown) of cement or a bonding agent. Alternatively, the expanded casing 8 may be secured to the borehole wall by friction. Such friction may be generated by providing the outer surface of the casing 8 with spikes (not shown) and/or by radially pressing the casing into the formation 3.

Subsequently, the drill bit is lowered through the upper casing 8 to the bottom of the first borehole section 1A and the second section 1B of the borehole 1 is drilled. After the next interface 13 has been reached, the second casing 9 is lowered through the first casing 8 to the bottom of the second borehole section 1B and radially expanded by means of the expansion mandrel 16.

When the expansion mandrel 16 reaches the area where the casings 8 and 9 co-axially overlap each other the second casing 9 will further expand the first casing 8 which generates a strong bond and seal generated by frictional and compressive forces. In order to alleviate



the increased expansion forces at the area of overlap the length over which the casings 8 and 9 overlap each other is relatively small, preferably less than 10% of the length of the shortest casing 8 and 9 and the bottom of the upper casing 8 may be pre-expanded and/or provided with slits or grooves (not shown) which widen up or break open during the expansion process.

The second casing 9 is secured to the borehole wall in the same way as the first casing 8. Furthermore the second and any further borehole sections 1B, 1C and 1D are drilled by means of an underreamer bit which is able to drill the whole length of the borehole 1 at substantially the same diameter.

Subsequently, the third and fourth borehole sections 1C and 1D are each drilled and cased in the same manner as described with reference to the second borehole section 1B.

At the bottom of section 1D there is shown the expansion mandrel 16 which is moved downwardly in longitudinal direction through the lowermost casing 11, thereby radially expanding the casing 11 in a manner which is described in more detail with reference to Fig. 4.

Referring now to Fig. 2 there is shown the borehole 1 of Fig. 1 in which a production tubing 17 is being installed by longitudinally moving an expansion mandrel 18 therethrough.

The tubing 17 is expanded to an outer diameter which is substantially equal to the inner diameter of the expanded casings so that the production tubing 17 forms an internal cladding to the casings 8, 9, 10 and 11 and the walls of the tubing 17 and casings 8, 9, 10 and 11 mutually reinforce each other. The lower end of the production tubing that extends beyond the lower end of

the lowermost casing 11 into the oil and/or gas bearing formation 7 may be provided with staggered axial slots (not shown) which open up to a diamond shape as a result of the pipe expansion process in order to permit inflow of oil and/or gas from the formation 7 into the borehole 1, which fluids then flow up through the interior of the tubing 17 to the earth surface 2.

Instead of providing the inflow section at the lower end of the production tubing 17 with axial slots, it may be provided with non-slotted apertures as well. These apertures may be circular, oval or square holes that are punched into, or cut away from, the tubing wall and which are arranged in an overlapping or non-overlapping pattern which may be staggered or not.

The presence of such non-slotted apertures creates a tubing which will, after expansion thereof, generally have a higher strength than an expandable tubing with overlapping staggered axial slots.

Also the expandable casings 8, 9, 10 and 11 may be provided with at least some slotted or non-slotted apertures in order to alleviate the forces required to expand these casings, in particular in the areas where the casings 8, 9, 10 and 11 overlap each other and in other areas, such as curved sections of the borehole 1, where expansion forces are high.

It will be understood that in such case the production tubing 17 is not perforated in the areas where any of the casings 8, 9, 10 and 11 is perforated so as to retain a fluid tight seal between the interior of the tubing 17 and the surrounding formation layers 3, 4, 5 and 6.

Referring now to Fig. 3 there is shown a borehole 20 that has been drilled into an underground formation 21.

In the upper part of the borehole 20A a first

casing 22 is installed and expanded. In the example shown the upper part of the borehole 20A has an internal diameter of about 25.4 cm. The unexpanded first casing 22 has an outer diameter of about 18.8 cm when it is lowered into the borehole. The expanded first casing 22 has an outer diameter of about 23.4 cm so that a small annulus is left around the expanded first casing 22 which is filled with cement 23.

Subsequently the second part of the borehole 20B is drilled to an internal diameter of about 21 cm and a second casing 24 is inserted in unexpanded form into the borehole such that it extends from the top of the borehole 20 to the bottom of the second part 20B thereof. The unexpanded second casing 24 has an outer diameter of 15.7 cm and is expanded inside the borehole 20 to an outer diameter of 19.5 cm.

The second casing 24 is cemented inside the second part of the borehole 20B and inside the first casing by an annular body of cement 23.

Then a third borehole section 20C having an internal diameter of 17.8 cm is drilled from the bottom of the second borehole section 20B into the formation 21, whereupon a third casing section 25 is inserted into the borehole 20 and expanded. The unexpanded third casing 25 has an outer diameter of about 13 cm and is expanded to an outer diameter of about 16.3 cm.

Thereafter a fourth borehole section 20D having an internal diameter of about 14.2 cm is drilled and a fourth casing 26 is inserted into the borehole 20 and subsequently expanded from an outer diameter of 10.1 cm to an outer diameter of about 13 cm.

Inside the fourth casing 26 a production tubing 27 is inserted and expanded against the inner surface of said casing 26 to form a clad tubing 27.

To facilitate injection of service and/or kill fluids into the well and to permit installation of conduits for measuring or other equipment a coiled service conduit 28 is inserted into the production tubing 27 and sealingly connected near the bottom of the tubing 27 by a production packer 29.

The service conduit 28 contains perforations 30 just above the production packer so that oil and/or gas can be produced from the inflow region of the well, the bottom of the service conduit 28 and the perforations 30 into the production tubing 27.

As a result of the expansion of the casings 22, 24, 25 and 26 and of the production tubing 27 it is possible that a production tubing having an internal diameter of more than 10 cm is installed in a borehole 20 of which the upper section 20A has an internal diameter of about 25 cm. It will be understood by those skilled in the art of drilling of oil and/or gas production wells that the method according to the invention facilitates the use of a larger diameter production tubing 27 inside a smaller diameter borehole 20 than conventional well drilling and completion techniques.

It will also be understood that instead of using only expanded casings inside the borehole one or more casings may still be an unexpandable conventional casing. For example the upper casing may be a conventional casing, in which one or more telescoping expandable casing sections, as shown in Fig. 3, are inserted and the lower part of the borehole may be equipped with monobore casings as shown in Fig. 1 and 2.

Now referring to Fig. 4, there is shown a borehole traversing an underground formation 41 and a casing 42 that is fixed within the borehole by means of an annular body of cement 43.

A production tubing 44 which is made of a dual phase, high-strength low-alloy (HSLA) steel or other formable high-strength steel is suspended within the casing 42.

5 An expansion mandrel 45 is moved in longitudinal direction through the tubing 44 thereby expanding the tubing 44 such that the outer diameter of the expanded tubing is slightly smaller than, or is about equal to, the internal diameter of the casing 42.

10 The expansion mandrel 45 is equipped with a series of ceramic surfaces 46 which restrict frictional forces between the pig and tubing 44 during the expansion process. In the example shown the semi top angle A of the conical ceramic surface that actually expands the tubing is about 25°. It has been found that zirconium oxide is a  
15 suitable ceramic material which can be formed as a smooth conical ring. Experiments and simulations have shown that if the semi cone top angle A is between 20° and 30° the pipe deforms such that it obtains an S-shape and touches the tapering part of the ceramic surface 46 essentially  
20 at the outer tip or rim of said conical part and optionally also about halfway the conical part.

The experiments also showed that it is beneficial that the expanding tubing 44 obtains an S-shape since this reduces the length of the contact surface between  
25 the tapering part of the ceramic surface 46 and the tubing 44 and thereby also reduces the amount of friction between the expansion mandrel 45 and the tubing 44.

Experiments have also shown that if said semi top angle A is smaller than 15° this results in relatively  
30 high frictional forces between the tube and pig, whereas if said top angle is larger than 30° this will involve redundant plastic work due to plastic bending of the tubing 44 which also leads to higher heat dissipation and to disruptions of the forward movement of the pig 45

through the tubing 44. Hence said semi top angle A is preferably selected between 15° and 30° and should always be between 5° and 45°.

5 Experiments have also shown that the tapering part of the expansion mandrel 45 should have a non-metallic outer surface to avoid galling of the tubing during the expansion process. The use of a ceramic surface for the tapering part of the expansion mandrel furthermore caused the average roughness of the inner surface of the  
10 tubing 44 to decrease as a result of the expansion process. The experiments have also shown that the expansion mandrel 45 provided with a ceramic tapering surface 46 could expand a tubing 45 made of a formable steel such that the outer tubing diameter D2 after  
15 expansion was at least 20% larger than the outer diameter D1 of the unexpanded tubing and that suitable formable steels are dual phase (DP) high-strength low alloy (HSLA) steels known as DP55 and DP60; ASTM A106 HSLA seamless pipe, ASTM A312 austenitic stainless steel pipes, grades  
20 TP 304 L and TP 316 L and a high-retained austenite high-strength hot rolled steel, known as TRIP steel manufactured by the Nippon Steel Corporation.

The mandrel 45 is provided with a pair of sealing rings 47 which are located at such a distance from the  
25 conical ceramic surface 46 that the rings 47 face the plastically expanded section of the tubing 44. The sealing rings serve to avoid that fluid at high hydraulic pressure would be present between the conical ceramic surface 46 of the mandrel 45 and the expanding tubing 44  
30 which might lead to an irregularly large expansion of the tubing 44.

The expansion mandrel 45 is provided with a central vent passage 47 which is in communication with a coiled vent line 48 through which fluid may be vented to the

surface. After completion of the expansion process the pig 45 may be pulled up to surface by the vent line and a coiled kill and/or service line (not shown) may be lowered into the expanded tubing 44 to facilitate injection of kill and/or treatment fluids towards the hydrocarbon fluid inflow zone which is normally be done via the annulus between the production tubing and the well casing. However, if the tubing 44 is expanded to a smaller diameter then the residual annular space between the casing 42 and expanded tubing 44 can be used for venting of fluids during the expansion process and for injection of fluids during the production process, in which case there is no need for using a vent line 48 and kill and/or service lines.

In conventional wells it is often necessary to use a production tubing having an outer diameter which is less than 50% of the inner diameter of the innermost well casing to enable a smooth insertion of the tubing even if the well is deviated and the casing has an irregular inner surface. Therefore it is apparent that the in-situ tubing expansion method according to the present invention enhances an efficient use of the wellbore.

It will be understood that instead of moving the expansion mandrel 45 through the tubing 44 by means of hydraulic pressure, the mandrel can also be pulled through the tubing by means of a cable or pushed through the tubing by means of pipe string or rod.

It will also be understood that the casing 42 and the casings 8, 9, 10, 11, 22, 24, 25 and 26 that are shown in Fig. 1, 2 and 3 can be expanded using a similar expansion process as described for the expansion of the tubing 44 with reference to Fig. 4, if these casings are also made of a formable steel grade.

Preferably the expandable production tubing and

expandable casings are made of a formable steel grade having a yield strength-tensile strength ratio which is lower than 0.8 and a yield strength which is at least 275 MPa.

5           The invention will now be further described on the basis of the following comparative experiments.

Experiment 1

10           An expansion mandrel having a conical ceramic surface (semi top angle A of cone = 20°) was moved through a conventional oil field tubular, known as casing grade L80 13% Cr, which is a widely used casing type, having an initial outer diameter of 101.6 mm (4"), an initial wall thickness of 5.75 mm, a burst pressure of 850 bar and a strain hardening exponent  $n = 0.075$ . The expansion  
15           mandrel was designed such that the outer diameter of the expanded tubular would be 127 mm, so that the increase in diameter would be 20%. The tubular burst during the expansion process. Analysis showed that the ductility limit of the material had been exceeded so that ductile  
20           fracturing occurred.

Experiment 2

25           An experiment was carried out with a coiled tubing of the type QT-800 which is increasingly used as a production tubing in oil or gas wells. The tubing had an initial outer diameter of 60.3 mm, a wall thickness of 5.15 mm, a burst pressure of 800 bar and a strain hardening exponent  $n = 0.14$ . An expansion mandrel was moved through the tubing which mandrel comprised a  
30           conical ceramic surface such that the semi top angle A of a cone enveloping the conical surface was 5° and which was designed such that the outer diameter of the expanded tubing would be 73 mm (increase of about 21%). This tubing burst during the expansion process. Analysis revealed that due to high friction forces the expansion



pressure had exceeded the burst pressure of the pipe during the expansion process.

### Experiment 3

5 An experiment was carried out with a seamless pipe made of a formable steel grade known as ASTM A 106 Grade B. The pipe had an initial outer diameter of 101.6 mm (4"), an initial wall thickness of 5.75 mm and a strain hardening exponent  $n = 0.175$ .

10 An expansion mandrel was pumped through the pipe, which mandrel comprised a ceramic conical surface such that the semi top angle  $A$  of a cone enveloping the conical surface was  $20^\circ$  and such that the outer diameter of the expanded pipe was 127 mm (5") and the outer diameter increased by 21%.

15 The pipe was expanded successfully and the hydraulic pressure exerted to the mandrel to move the mandrel through the pipe was between 275 and 300 bar. The burst pressure of the expanded pipe was between 520 and 530 bar.

---

C L A I M S

1. A method for drilling and completing a hydrocarbon production well, the method comprising the steps of:  
A) drilling a section of a borehole into an underground formation; inserting a casing into the drilled borehole section and radially expanding and securing the casing within said borehole section;  
5  
B) lowering a drill bit through the expanded casing and drilling a subsequent section of the borehole; inserting a next casing into said subsequent section of the borehole and radially expanding and securing said next casing within said subsequent borehole section; and  
10  
C) repeating, if required, step B a number of times until the borehole has reached the vicinity of a hydrocarbon bearing formation.
- 15 2. The method of claim 1, wherein only the first casing extends from the earth surface into the borehole and any subsequent casing only partly overlaps a previously set casing.
- 20 3. The method of claim 2, wherein the length along which subsequent casing sections overlap each other is less than 10% of the length of each casing itself.
- 25 4. The method of claim 3, wherein along at least a substantial part of the length of the borehole from the earth surface to the vicinity of the hydrocarbon bearing formation the variation in diameter of the borehole is less than 10%.
5. The method of claim 1, wherein at least two casings that are subsequently inserted into the borehole each extend to the wellhead.
- 30 6. The method of claim 1, wherein after installing said

casings a production tubing is inserted into the borehole such that the production tubing extends from the earth surface to the vicinity of the hydrocarbon formation; and radially expanding the tubing inside the string of expanded casings.

5

7. The method of claim 1 or 6, wherein the casings and optionally the tubing are plastically expanded in radial direction by moving an expansion mandrel therethrough in a longitudinal direction and are made of a formable steel grade which is subject to strain hardening without incurring any necking and ductile fracturing as a result of the expansion process and wherein an expansion mandrel is used which has along part of its length a tapering non-metallic surface.

10

15

8. The method of claim 7, wherein the expansion mandrel has a tapering ceramic surface and the tubing and casings are made of a formable steel grade having a yield strength-tensile strength ratio which is lower than 0.8 and a yield strength of at least 275 MPa.

20

9. The method of claim 6, wherein the production tubing and at least one of the casings consists of a tubular which is inserted into the borehole by reeling the tubular from a reeling drum.

Fig. 1.

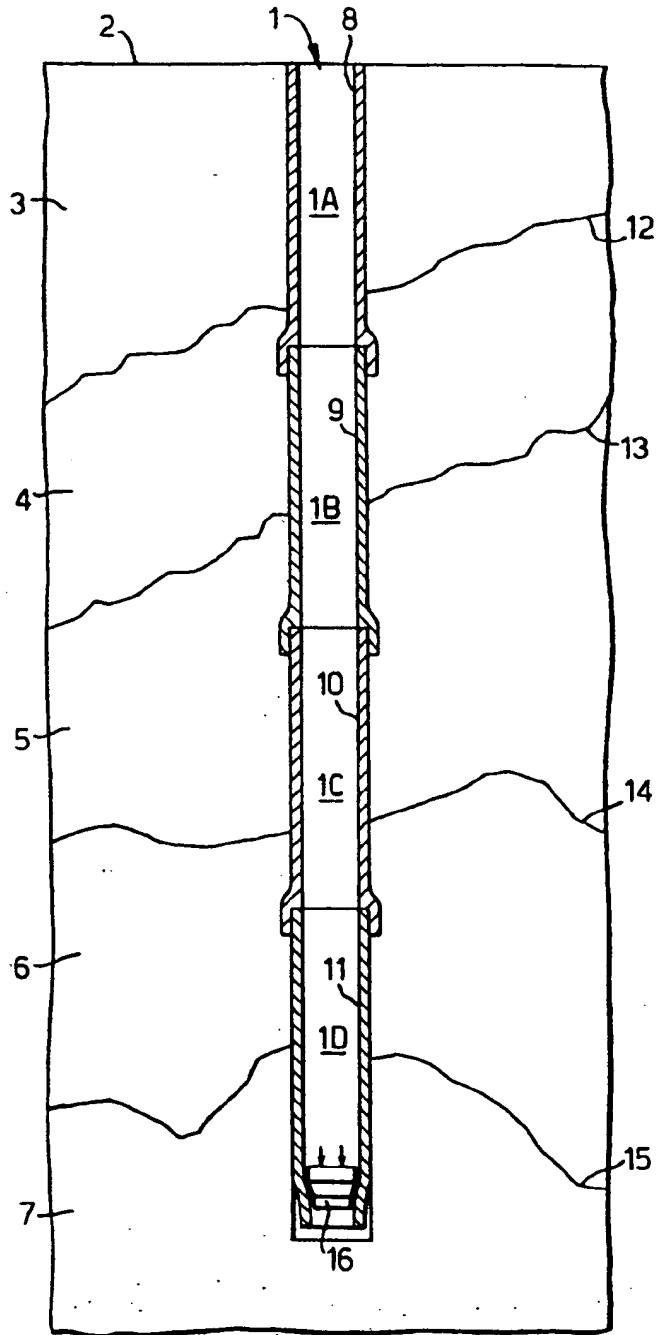

Fig.2.

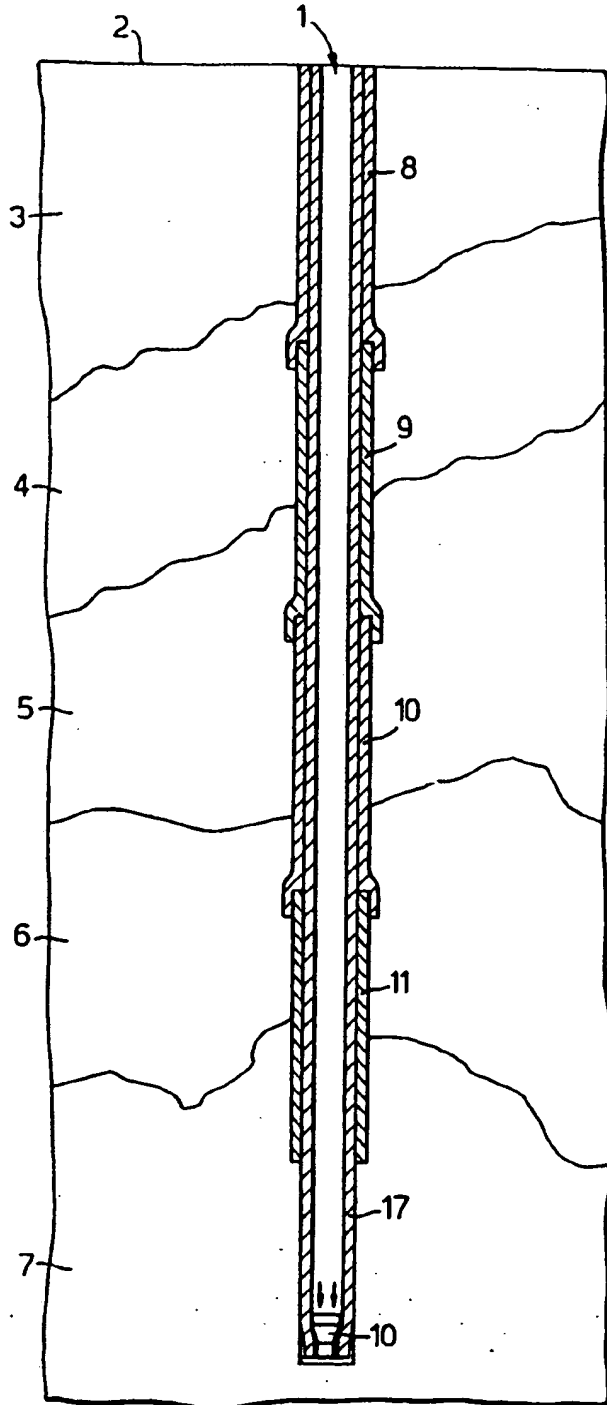

Fig.3.

